

Safety Valves

DN 15



ALICO



Safety Valves 1/2 x 1/2" KEC-PTFE

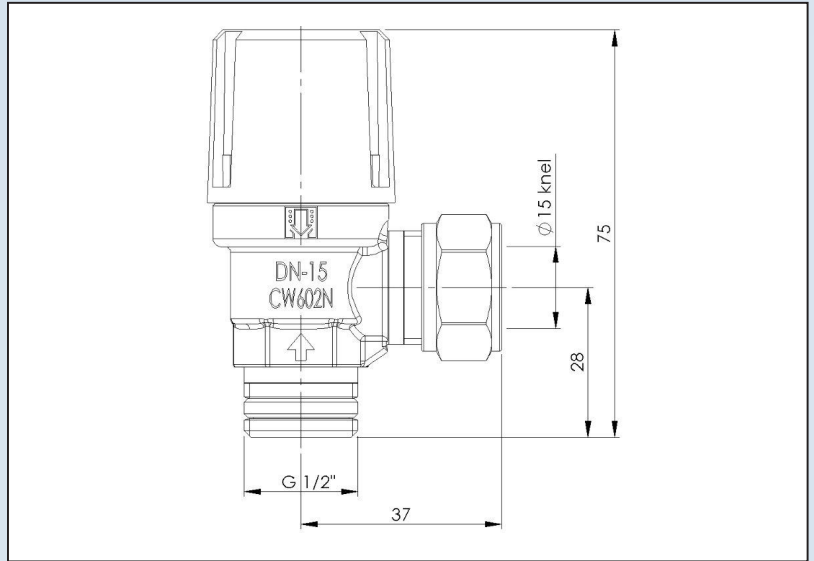
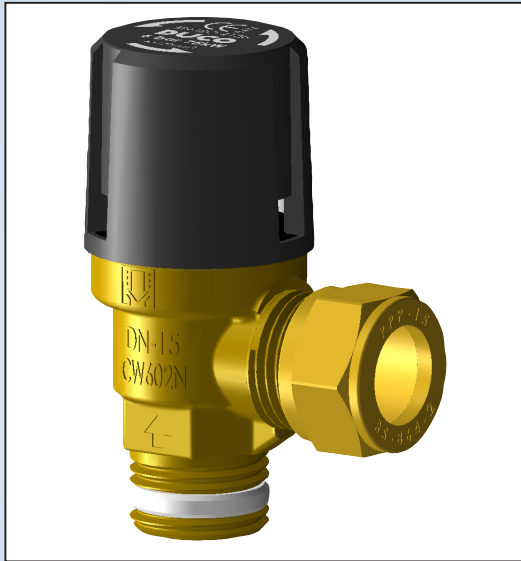

Duco safety valves to protect closed heated and chilled water systems against excessive pressure.

Application

The safety valve has to be used in a closed heating or cooling system (glycol max. 50%) Only use the Duco valve in a dry and frostfree location.

Min / max. system temp.: -10°C / +120°C

Safety

Check whether the max. capacity and the opening pressure that are indicated on the valve match the values of the system.



All Duco safety valves meet the requirements of the Pressure Equipment Directive (PED)

"Directive 2014/68/EU Module B/Module D"

The quality system also complies with the NEN-EN-ISO 9001

NORM: NEN-EN-ISO 4126-1

<i>Code</i>	<i>Set pressure (bar)</i>	<i>Heating capacity (kW)</i>
1050-0-01-11	0,5	48
1050-0-02-11	1	64
1050-0-04-11	2	93
1050-0-05-11	2,5	107
1050-0-06-11	3	120
1050-0-08-11	4	148
1050-0-10-11	5	175
1050-0-16-11	6	200
1050-0-17-11	7	226
1050-0-18-11	8	252
1050-0-19-11	9	278
1050-0-20-11	10	302

PenTec bv
Edisonweg 7
3442 AC Woerden
The Netherlands

Tel. +31 (0)182 503 100
E-mail info@pentecbv.nl
Internet www.duco.nl
www.pentecbv.nl

