

Safety Valves DN 15

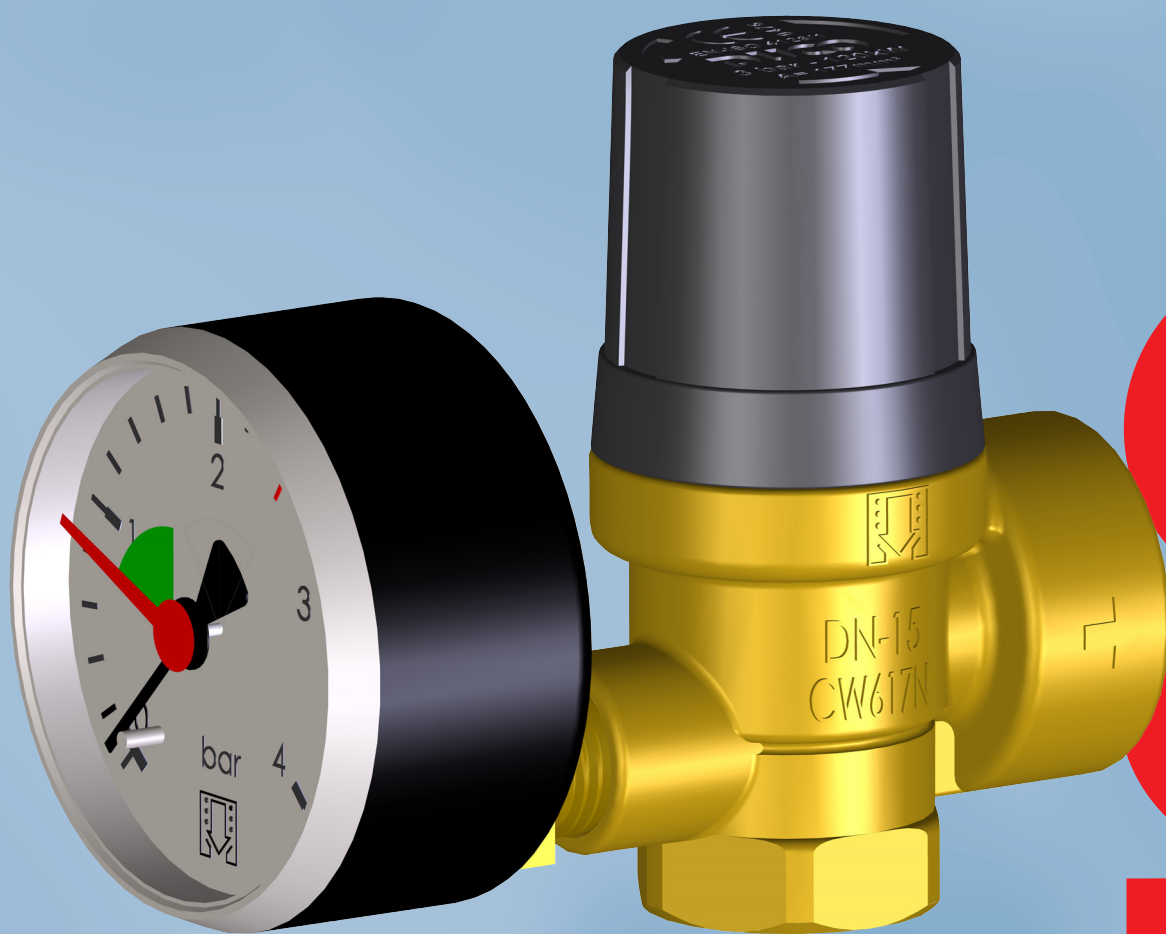

OSU



Safety Valves 1/2 x 3/4" KM

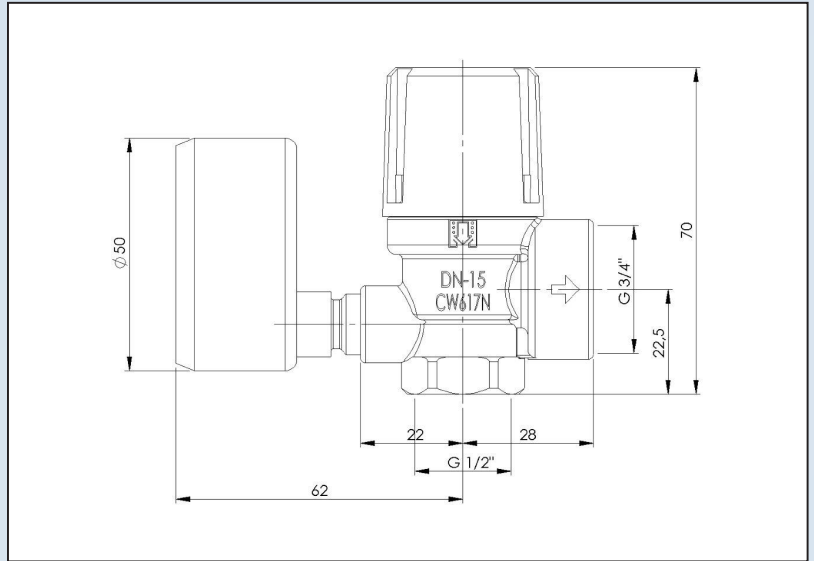
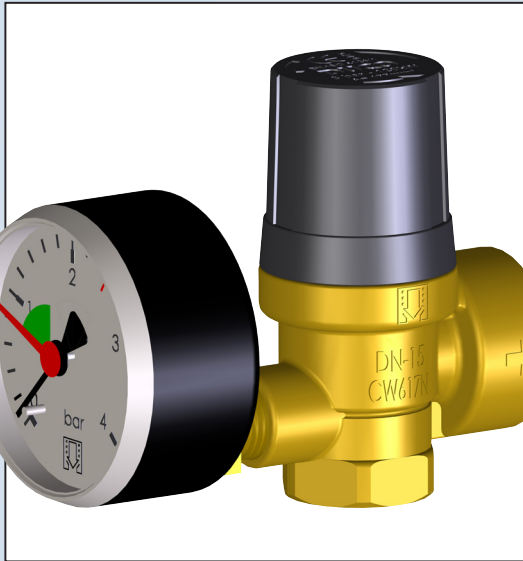

Duco safety valves to protect closed heated and chilled water systems against excessive pressure.

Application

The safety valve has to be used in a closed heating or cooling system (glycol max. 50%) Only use the Duco valve in a dry and frostfree location.

Min / max. system temp.: -10°C / +120°C

Safety

Check whether the max. capacity and the opening pressure that are indicated on the valve match the values of the system.



All Duco safety valves meet the requirements of the Pressure Equipment Directive (PED) "Directive 2014/68/EU Module B/Module D" The quality system also complies with the NEN-EN-ISO 9001

NORM: NEN-EN-ISO 4126-1

Code	Set pressure (bar)	Heating capacity (kW)
1055-0-21-11	0,5	48
1055-0-22-11	1	64
1055-0-24-11	2	93
1055-0-25-11	2,5	107
1055-0-26-11	3	120

PenTec bv
Edisonweg 7
3442 AC Woerden
The Netherlands

Tel. +31 (0)182 503 100
E-mail info@pentecbv.nl
Internet www.duco.nl
www.pentecbv.nl

