

Radiator Valves M22 - M24 for 2 pipe systems

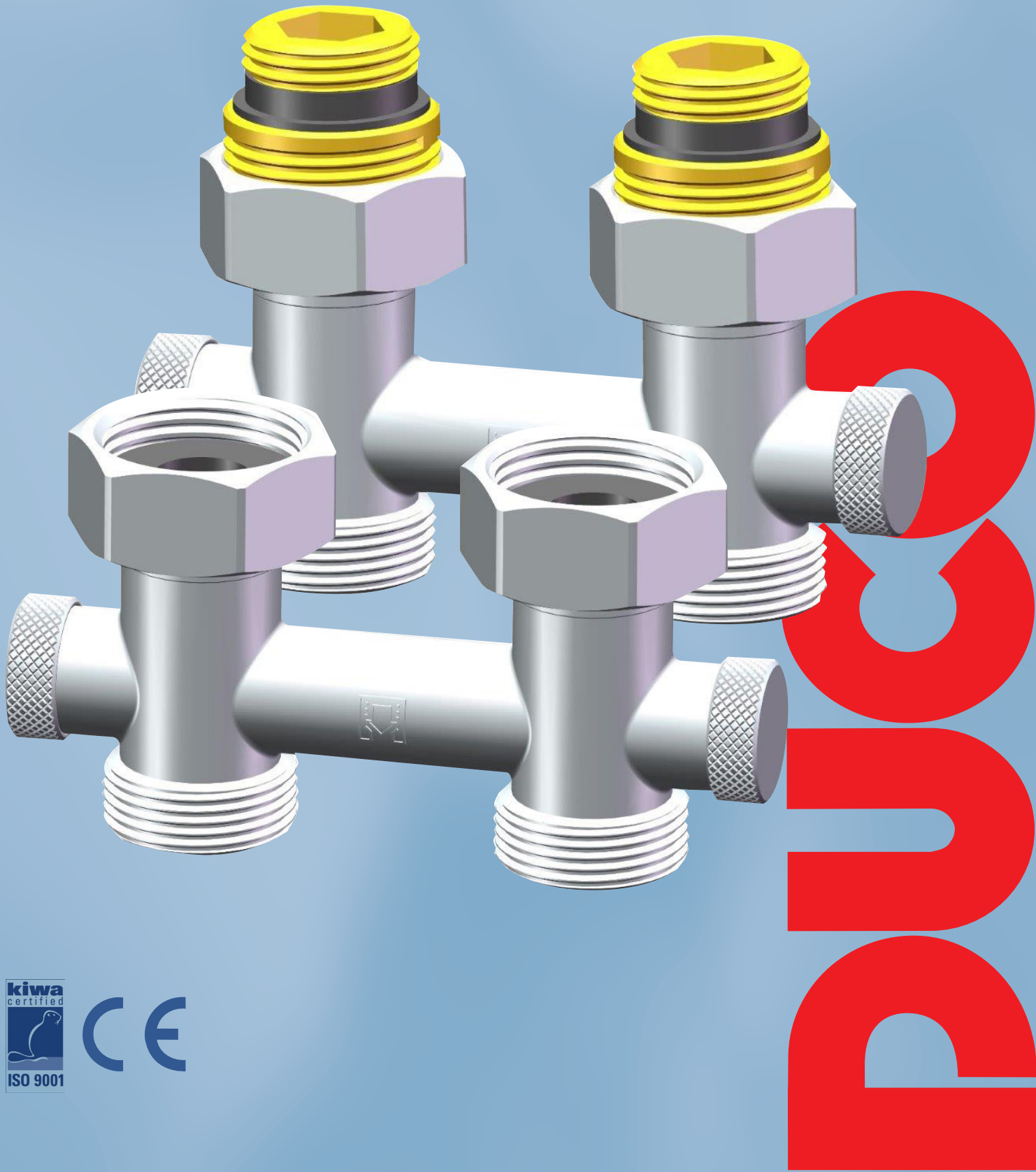

Radiator Valves M22 - M24 for 2 pipe systems

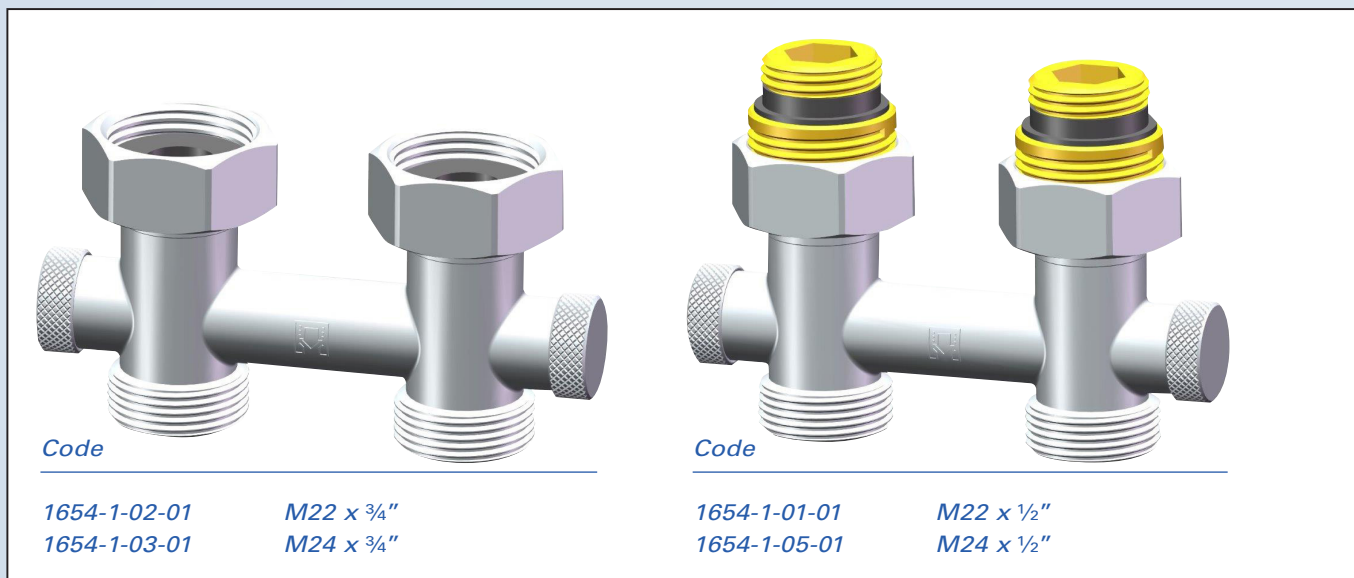

A big advantage of a 2 pipe system is the possibility to adjust the heat (flow) at each radiator independently. By means of the adjustable spindles you can regulate/adjust the flow and also close the supply and return of the valve (in case of removing the radiator).

Max. working temperature: 100°C

Max. working pressure: 4 bar

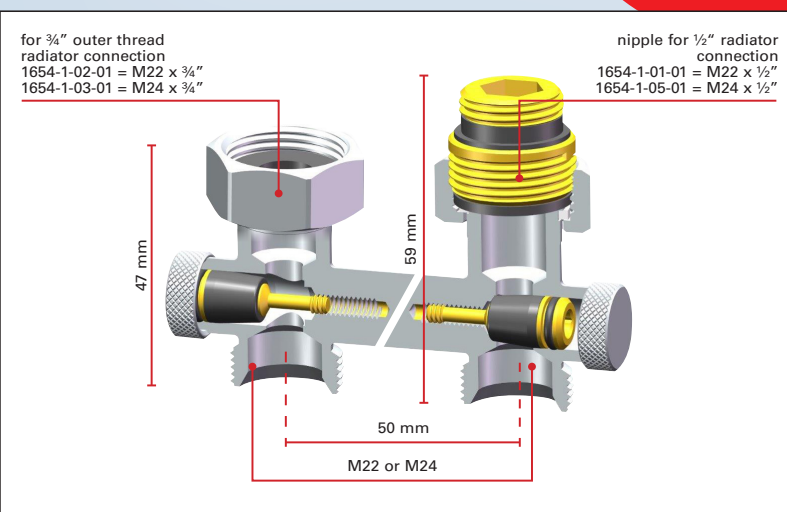
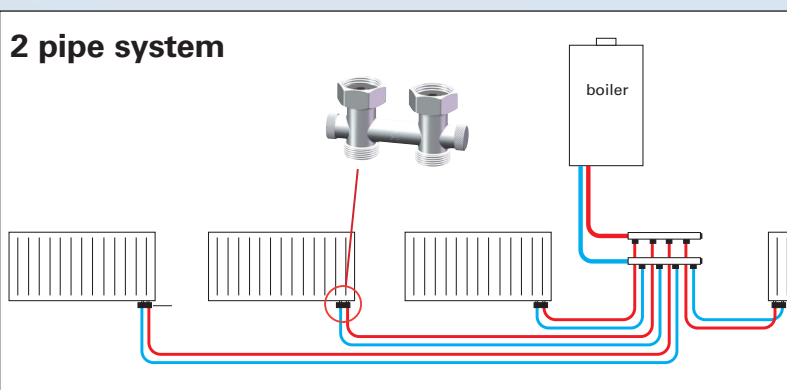

PenTec bv
Edisonweg 7
3442 AC Woerden
The Netherlands

Tel. +31 (0)182 503 100
E-mail info@pentecbv.nl
Internet www.duco.nl
www.pentecbv.nl