

# Boiler Safety Valves DN15



**PUCO**

# Boiler Safety Valves ½ x ½" KB

DUCO boiler valves to protect closed potable heated water systems against excessive pressure.

## Application

The boiler valve has to be used in a closed drinking water system.  
Only use the valve in a dry and frostfree location.  
Min/Max. system temp. 0°C / + 95°C

## Safety

Check whether the max. capacity and the opening pressure that are indicated on the valve match the values of the system.

All Duco safety valves meet the requirements of the Pressure Equipment Directive (PED) "Directive 2014/68/EU Module B/Module D". The quality system also complies with the NEN-EN-ISO 9001.

NORM: NEN-EN 1491

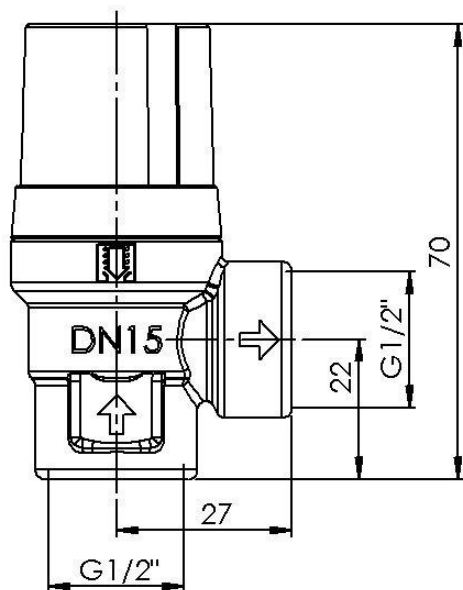

## Safety Valves DN32

Article number	Set pressure bar	Heating capacity kW
1065-0-16-11	6	75
1065-0-17-11	7	75
1065-0-18-11	8	75
1065-0-19-11	9	75
1065-0-20-11	10	75



**kiwa** 

# PUCO

PenTec bv  
Edisonweg 7  
3442 AC Woerden  
The Netherlands

Tel. +31 (0)182 503 100  
E-mail info@pentecbv.nl  
Internet www.duco.nl  
www.pentecbv.nl