

Boiler Safety Unit DN 20



DUCO



Boiler Safety Unit DN20

22 mm compression

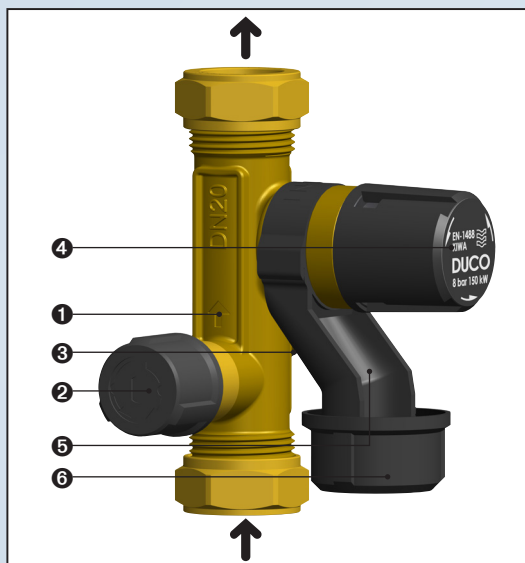

- ❶ Flow arrow
- ❷ Shut-off valve
- ❸ Test plug
- ❹ Relief valve
- ❺ 360° Rotatable funnel
- ❻ Adapter flexible hose

The Boiler Safety Unit is installed in connection with domestic water heaters (fired by electric, gas or oil) and must be fitted to the cold water inlet.

The purpose of the use of this safety unit is

- 1) supply of water
- 2) being able to shut off the supply line
- 3) protecting against overpressure of the water heater
- 4) preventing warm water from flowing back into the cold water supply line.

The Boiler Safety Unit can be mounted vertically or horizontally.

Before installing the Boiler Safety Unit please check our installation instructions.

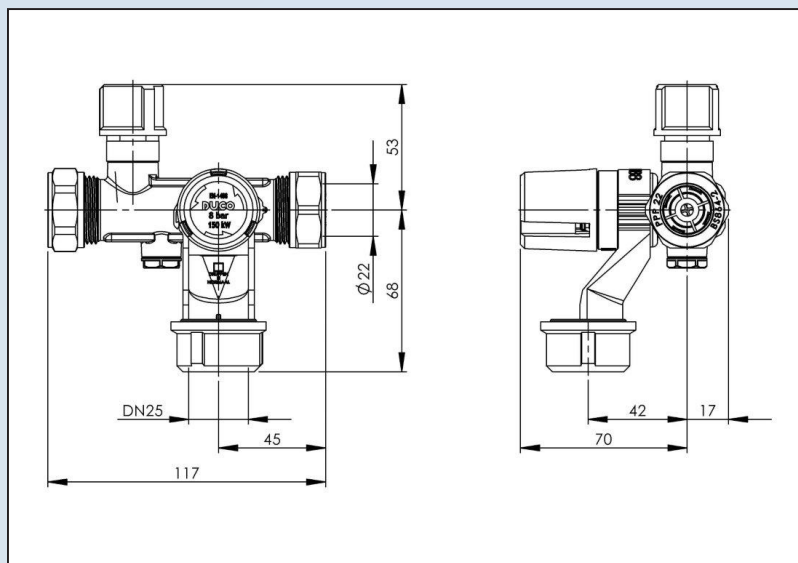

Code	set pressure (bar)	max. capacity water heater (kW)
1203-0-06-01	6	150*
1203-0-07-01	7	150
1203-0-08-01	8	150*
1203-0-09-01	9	150
1203-0-10-01	10	150*

* certified

Continuous operating temperature max. 65°C/
peak load max. 90°C (1 hour).
Max. cap. 6.200 L/h. at 1 bar (10kPa)
differential pressure.

In accordance with the EN 1488 the Boiler Safety Unit is available in 6, 7, 8, 9 and 10 bar.

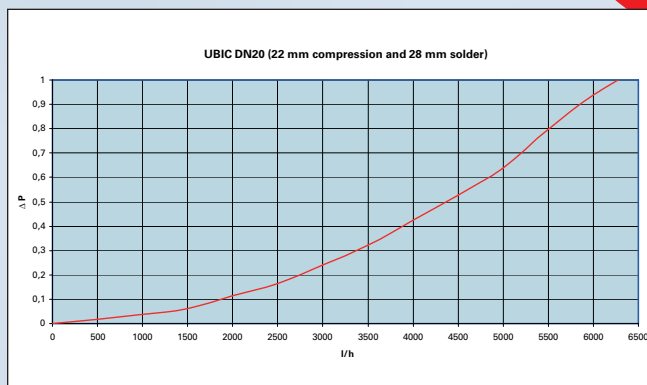

PenTec bv
Edisonweg 7
3442 AC Woerden
The Netherlands

Tel. +31 (0)182 503 100
E-mail info@pentecbv.nl
Internet www.duco.nl
www.pentecbv.nl

