

Thermostatic Mixing Valve DN20



WUOL



Thermostatic Mixing Valve DN20 T-Mix 3/4"

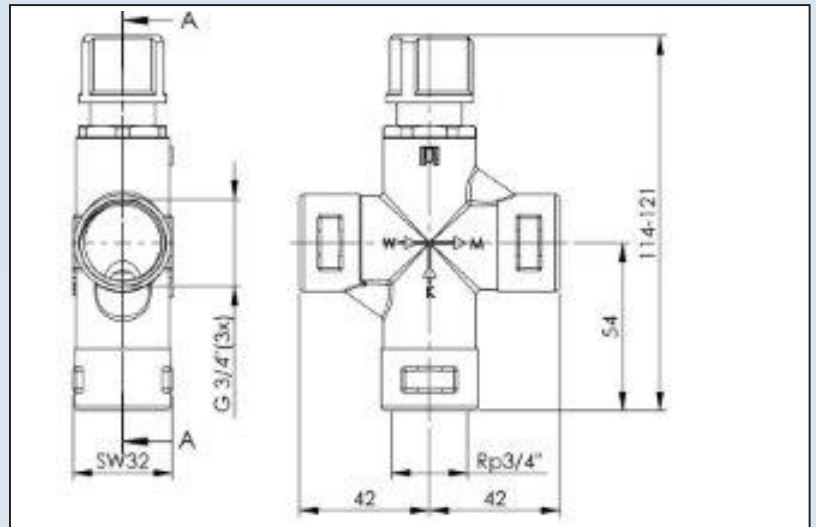
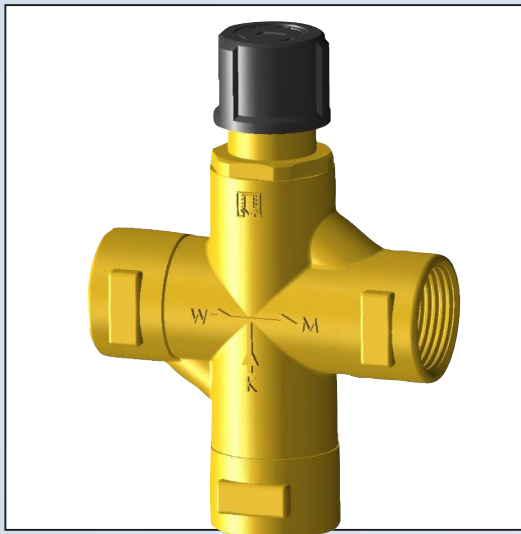

Thermostatic Mixing Valves mix the hot and cold water supplies to ensure constant, safe shower and bath outlet temperatures, preventing scalding.

Hot water for sanitary use must be kept at a temperature of at least 60°C or higher in order to control any growth of Legionella bacteria. However, such water is too hot for immediate use. The Thermostatic Mixing Valve will reduce the temperature down to a pleasant, safe and constant level. The Thermostatic Mixing Valve is mounted between the hot water appliance and the taps of the sanitary facilities. The aim is to keep the mixing water used at the taps at a constant, pre-set temperature.

The Thermostatic Mixing Valve has a control element/sensor. Through expansion and contraction, this sensor continuously controls the flow of hot and cold water. The mix water temperature can be set between 30°C and 70°C (by turning the black knob on top of the valve).

setting range	30 - 70°C
max. working pressure	14 bar
min. working pressure	0,2 bar
max. hot water temperature	85°C
flowrate	1.200 l/h - 1 bar
brass body	CW625N



PenTec bv
Edisonweg 7
3442 AC Woerden
The Netherlands

Code

1351-0-20-01

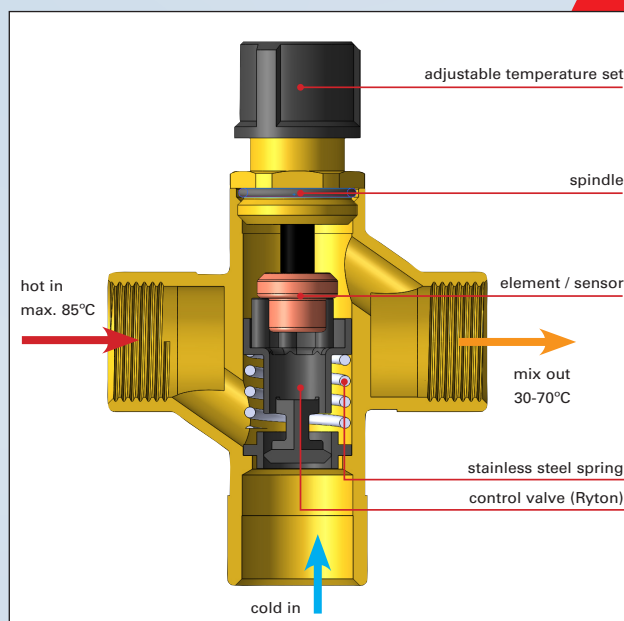
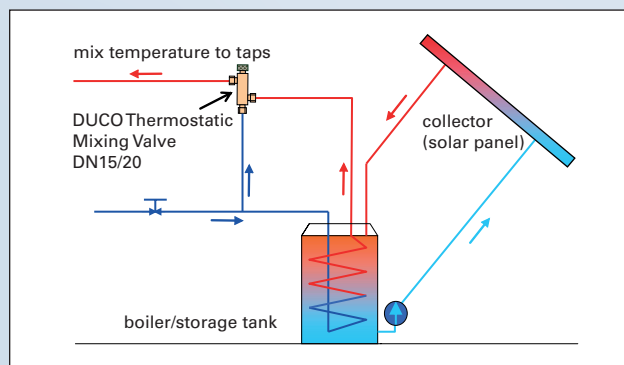

Tel. +31 (0)182 503 100
E-mail info@pentecbv.nl
Internet www.duco.nl
www.pentecbv.nl