

Boiler Safety Valves DN50



DUCO

Boiler Safety Valves DN50 2 x 2½" KB

DUCO boiler valves to protect closed potable heated water systems against excessive pressure.

Application

The boiler valve has to be used in a closed drinking water system.

Only use the valve in a dry and frostfree location.

Min/Max. system temp. 0°C / + 95°C

Safety

Check whether the max. capacity and the opening pressure that are indicated on the valve match the values of the system.

All Duco safety valves meet the requirements of the Pressure Equipment Directive (PED) "Directive 2014/68/EU Module B/Module D". The quality system also complies with the NEN-EN-ISO 9001

NORM: NEN-EN 1491

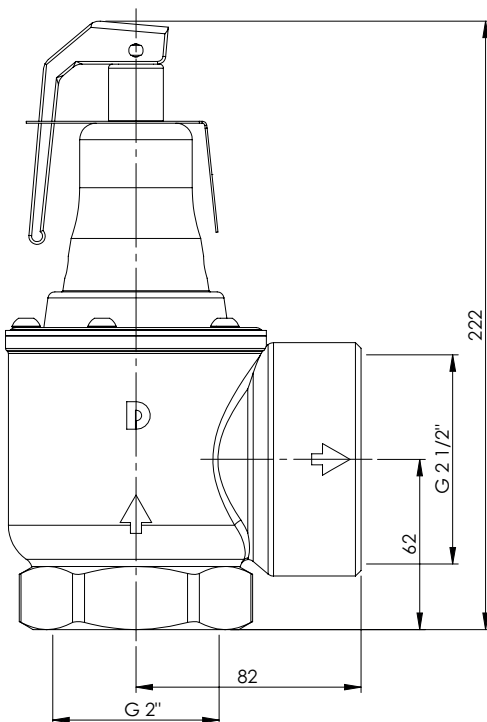

Safety Valves DN40

Article number	Set pressure bar	Heating capacity kW
1156-0-06-11	6	900
1156-0-07-11	7	900
1156-0-08-11	8	900
1156-0-09-11	9	900
1156-0-10-11	10	900

